

LOW-AND MEDIUM-VOLTAGE PIN TYPE INSULATOR(ANSI STANDARD)

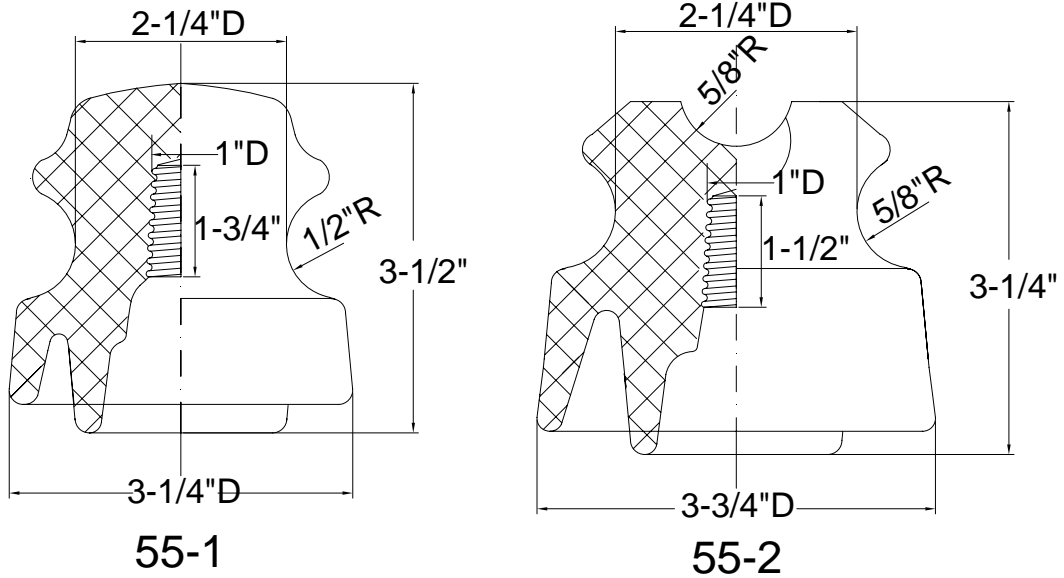

STANDARD PARTICULARS

Cat. No.		0401551		0401552		
ANSI Class		55-1		55-2		
Insulator Type		Plain	Radio Freed	Plain	Radio Freed	
Neck Designation in accordance with ANSI C29.5		C		C		
Voltage Rating (U.S.Practice) /kV		7.2		7.2		
Leakage Distance/in (mm)		4(102)		5(127)		
Dry Arcing Distance/in (mm)		2-1/4(57)		3-3/8(86)		
Minimum Pin Height/Average/lb (kN)		3,000(13.3)		2,500(11.1)		
Average Flashover Voltage	Low-frequency	Dry/kV	35	35	50	45
		Wet/kV	20	20	25	25
	Critical-impulse	Positive/kV	50	50	75	70
		Negative/kV	70	70	95	85
Low Frequency Puncture Voltage/Average/kV		50		70		
Radio-Influence Voltage	Test Voltage to Ground/kV	5	5	5	5	
Date	Maximum RIV at 1,000kHz/μV	2,500	50	2,500	50	
Net Weight/lb		1.2		1.4		

NOTES:1.Surfaces coated with semi-conductive glaze considered as effective leakage surfaces and the distance over them is included in the leakage distance.

2.Top-and wire groove shall seat a mandrel with a diameter of 15/16 inch.

LOW-AND MEDIUM-VOLTAGE PIN TYPE INSULATOR(ANSI STANDARD)

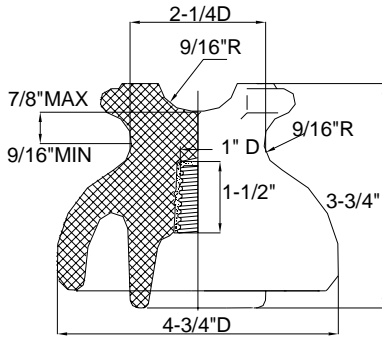

55-3

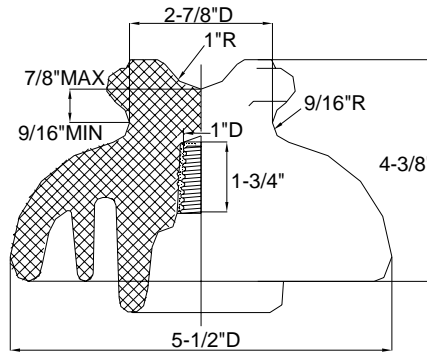

55-4

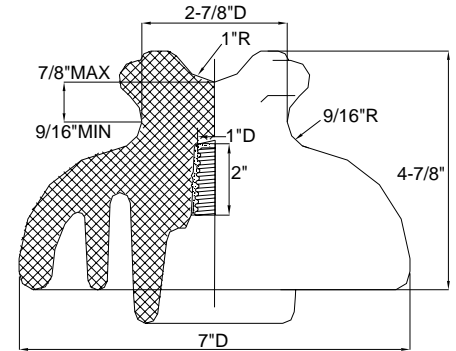

55-5

STANDARD PARTICULARS

Cat. No.		0401553		0401554		0401555		
ANSI Class		55-3		55-4		55-5		
Insulator Type		Plain	Radio Freud	Plain	Radio Freud	Plain	Radio Freud	
Neck Designation in accordance with ANSI C29.5		C		F		F		
Voltage Rating (U.S.Practice)/KV		7(178)		9(229)		12(305)		
Leakage Distance/in (mm)		4-1/2(114)		5(127)		6-1/4(159)		
Dry Arcing Distance/in (mm)		5(127)		5(127)		6(152)		
Cantilever Strength/Average/lb (kN)		2,500(11)		3,000(13)		3,000(13)		
Average Flashover Voltage	Low-frequency	Dry/kV	65	55	70	65	85	80
		Wet/kV	35	30	40	35	45	45
	Critical-impulse	Positive/kV	100	90	110	105	140	130
		Negative/kV	130	110	140	130	170	150
Low Frequency Puncture Voltage/Average/kV		90		95		115		
Radio-influence	Test Voltage to Ground/kV	10	10	10	10	15	15	
Voltage Date	Maximum RIV at 1,000kHz/ μ V	5,500	50	5,500	50	8,000	100	
Net Weight/lb		2.4		3.7		6.4		

NOTE:1.Surfaces coated with semi-conductive glaze are considered as effective leakage surfaces and the distance over them is included in the leakage distance.

2.The side-wire groove shall seat a mandrel with a diameter of 1-1/16 inches. The top-wire groove shall seat a mandrel with a diameter of 1-3/4 inches.

LOW-AND MEDIUM-VOLTAGE PIN TYPE INSULATOR(ANSI STANDARD)

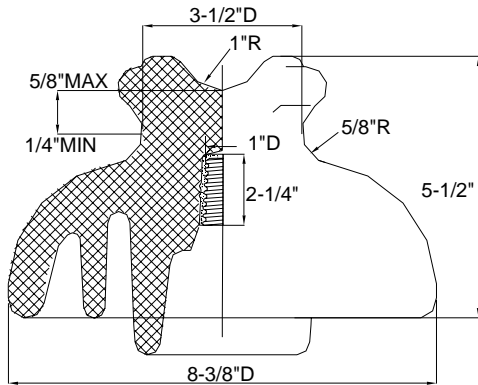

55-6

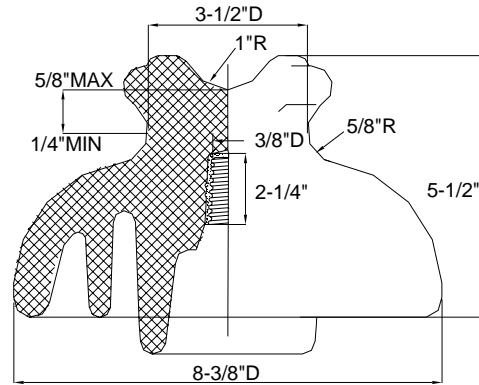

55-7

STANDARD PARTICULARS

Cat. No.		0401556	0401557
ANSI Class		55-6	55-7
Neck Designation in accordance with ANSI C29.5		J	J
Voltage Rating (U.S.Practice) /KV		13.2	13.2
Leakage Distance/in (mm)		15(381)	15(381)
Dry Arcing Distance/in (mm)		8(203)	8(203)
Minimum Pin Height/Average/lb (kN)		7-1/2(190)	7-1/2(190)
Average Flashover Voltage	Low-frequency	Dry/kV	100
		Wet/kV	50
	Critical-impulse	Positive/kV	150
		Negative/kV	170
Low Frequency Puncture Voltage/Average/kV		135	135
Radio-Influence Voltage Date	Test Voltage to Ground/kV		22
	Maximum RIV at 1,000kHz/μV	Radio Freed	100
		Plain	8000
Net Weight/lb		8.5	8.5

NOTE:1.Surfaces coated with semi-conductive glaze are considered as effective leakage surfaces and the distance over them is included in the leakage distance.

2.The side-wire groove shall seat a mandrel with a diameter of 1-1/8 inches. The top-wire groove shall seat a mandrel with a diameter of 1-3/4 inches.

HIGH-VOLTAGE PIN TYPE INSULATOR(ANSI STANDARD)

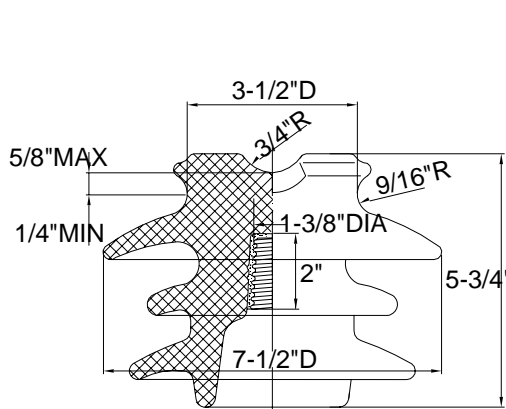

FIG. 1

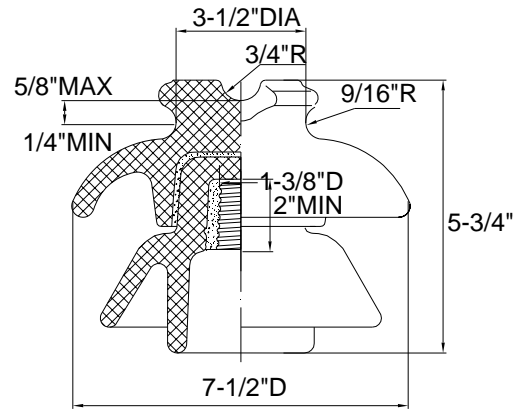

FIG. 2

56-1

STANDARD PARTICULARS

Cat. No.		0401561			
ANSI Class		56-1			
Fig. No.		1		2	
Insulator Type		Plain	Radio Freed	Plain	Radio Freed
Neck Designation in accordance with ANSI C29.5		J		J	
Voltage Rating (U.S.Practice) /KV		23		23	
Leakage Distance/in (mm)		13(330)		13(330)	
Dry Arcing Distance/in (mm)		7(178)		7(178)	
Minimum Pin Height/in (mm)		6(152)		6(152)	
Cantilever Strength/Average/lb (kN)		2,500(11)		2,500(11)	
Average Flashover Voltage	Low-frequency	Dry/kV	95	95	95
		Wet/kV	60	60	60
	Critical-impulse	Positive/kV	150	150	150
		Negative/kV	190	190	190
Low Frequency Puncture Voltage/Average/kV		130		130	
Radio-Influence Voltage	Test Voltage to Ground/kV		15	15	15
Date	Maximum RIV at 1,000kHz/μV		8,000	100	8,000
Net Weight/lb		7.3		7.3	

NOTES:1.Surfaces coated with semi-conductive glaze are considered as effective leakage surfaces and the distance over them is included in the leakage distance.

2.The side-wire groove shall seat a mandrel with a diameter of 1-1/16 inches. The top-wire groove shall seat a mandrel with a diameter of 1-3/4 inches.

HIGH-VOLTAGE PIN TYPE INSULATOR(ANSI STANDARD)

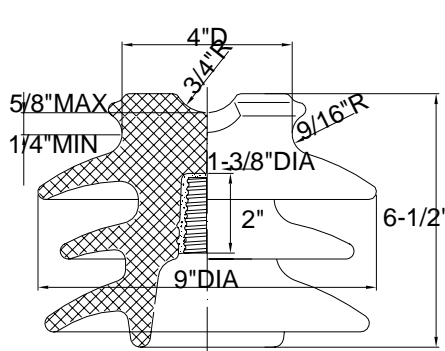

FIG. 1

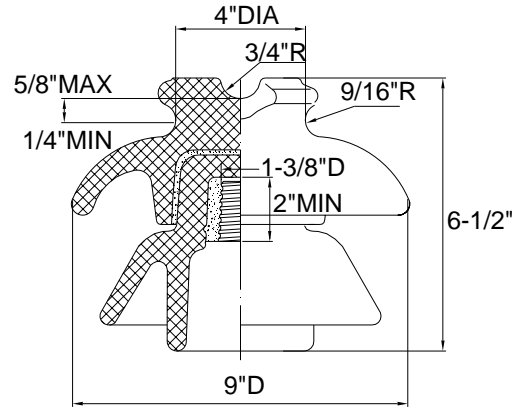

FIG. 2

56-2

STANDARD PARTICULARS

Cat. No.		0401562			
ANSI Class		56-2			
Fig. No.		1		2	
Insulator Type		Plain	Radio Freed	Plain	Radio Freed
Neck Designation in accordance with ANSI C29.6		K		K	
Voltage Rating (U.S.Practice) /KV		23		23	
Leakage Distance/in (mm)		17(432)		17(432)	
Dry Arcing Distance/in (mm)		8-1/4(210)		8-1/4(210)	
Minimum Pin Height/in (mm)		7(178)		7(178)	
Cantilever Strength/Average/lb (kN)		3,000(13)		3,000(13)	
Average Flashover Voltage	Low-frequency	Dry/kV	110	110	110
		Wet/kV	70	70	70
	Critical-impulse	Positive/kV	175	175	175
		Negative/kV	225	225	225
Low Frequency Puncture Voltage/Average/kV		145		145	
Radio-Influence Voltage	Test Voltage to Ground/kV	22	22	22	22
Date	Maximum RIV at 1,000kHz/μV	12,000	100	12,000	100
Net Weight/lb		11		11	

NOTE:1.Surfaces coated with semi-conductive glaze are considered as effective leakage surfaces and the distance over them is included in the leakage distance.

2.The side-wire groove shall seat a mandrel with a diameter of 1-1/16 inches. The top-wire groove shall seat a mandrel with a diameter of 1-7/16 inches.

HIGH-VOLTAGE PIN TYPE INSULATOR(ANSI STANDARD)

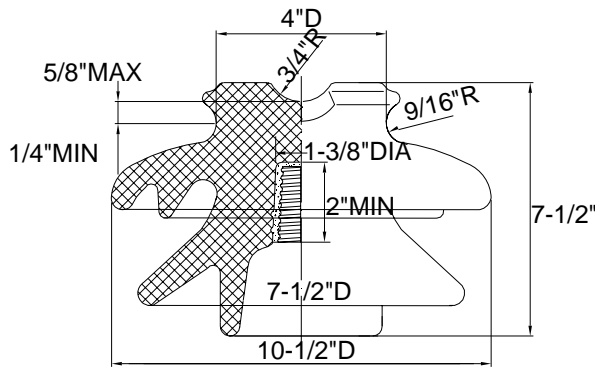

FIG. 1

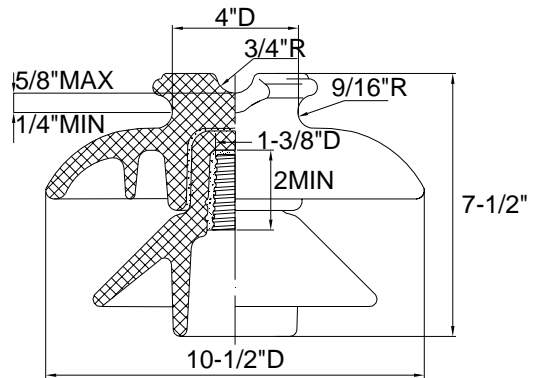

FIG. 2

56-3

STANDARD PARTICULARS

Cat. No.		0401563			
ANSI Class		56-3			
Fig. No.		1		2	
Insulator Type		Plain	Radio Freed	Plain	Radio Freed
Neck Designation in accordance with ANSI C29.6		K		K	
Voltage Rating (U.S.Practice) /kV		34.5		34.5	
Leakage Distance/in (mm)		21(533)		21(533)	
Dry Arcing Distance/in (mm)		9-1/2(241)		9-1/2(241)	
Minimum Pin Height/in (mm)		8(203)		8(203)	
Cantilever Strength/Average/lb (kN)		3,000(13)		3,000(13)	
Average Flashover Voltage	Low-frequency	Dry/kV	125	125	125
		Wet/kV	80	80	80
	Critical-impulse	Positive/kV	200	200	200
		Negative/kV	265	265	265
Low Frequency Puncture Voltage/Average/kV		165		165	
Radio-Influence Voltage	Test Voltage to Ground/kV	30	30	30	30
Date	Maximum RIV at 1,000kHz/μV	16,000	200	16,000	200
Net Weight/lb		17		17	

NOTES:1.Surfaces coated with semi-conductive glaze are considered as effective leakage surfaces and the distance over them is included in the leakage distance.

2 The side-wire groove shall seat a mandrel with a diameter of 1-1/16 inches. The top-wire groove shall seat a mandrel with a diameter of 1-7/16 inches.

STANDARD PARTICULARS(ANSI STANDARD)

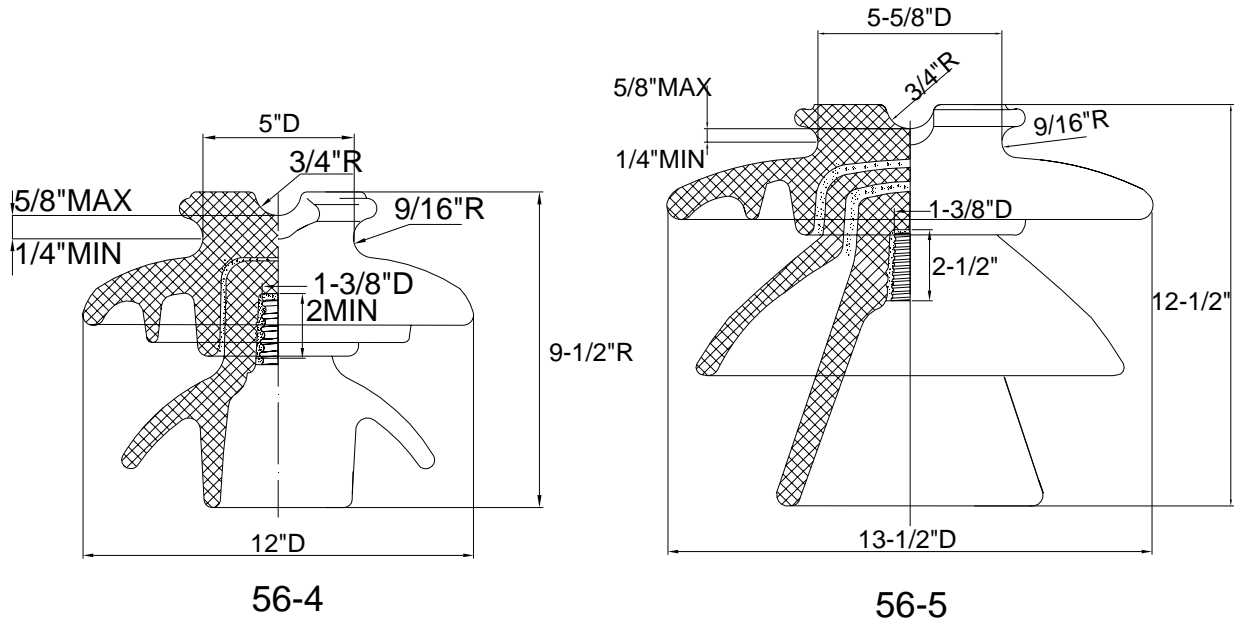

STANDARD PARTICULARS

Cat. No.		0401564		0401565	
ANSI Class		56-4		56-5	
Insulator Type		Plain	Radio Freed	Plain	Radio Freed
Leakage Distance/in (mm)		27(686)		34(864)	
Dry Arcing Distance/in (mm)		11-1/4(286)		14(356)	
Minimum Pin Height/in (mm)		10		12(305)	
Cantilever Strength/Average/lb (kN)		3,000 (13)		3,000(13)	
Average Flashover Voltage	Low-frequency	Dry/kV	140	175	
		Wet/kV	95	125	
	Critical-impulse	Positive/kV	225	270	
		Negative/kV	310	340	
Low Frequency Puncture Voltage/Average/kV		185		225	
Radio-Influence Voltage	Test Voltage to Ground/kV	30	30	44	44
Date	Maximum RIV at 1,000kHz/ μ V	16,000	200	25,000	200
Net Weight/lb		24		30	

NOTES:1.Surfaces coated with semi-conductive glaze are considered as effective leakage surfaces and the distance over them is included in the leakage distance.

2 The side-wire groove shall seat a mandrel with a diameter of 1-1/16 inches. The top-wire groove shall seat a mandrel with a diameter of 1-7/16 inches.

PIN TYPE INSULATOR (BS STANDARD)

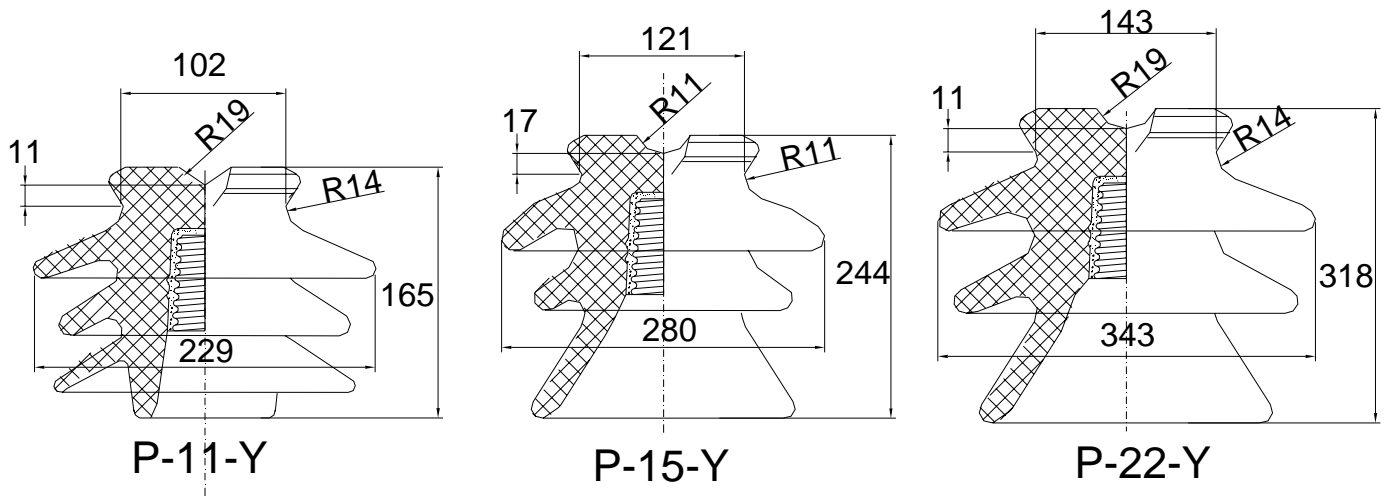

STANDARD PARTICULARS

Cat. No.		0402011		0402015		0402022	
ANSI Class		P-11-Y		P-15-Y		P-22-Y	
Insulator Type		Plain	Radio Freed	Plain	Radio Freed	Plain	Radio Freed
Recommended Nominal System Voltage/kV		11		15		22	
Total Creepage Distance/mm		254		298		432	
Protected Creepage Distance/mm		102		133		200	
Recommended Pin Height/mm		152		165		178	
Cantilever Strength/kN		11		11		11	
Minimum Flashover Voltage	Power-Frequency	Dry/kV	75	80	100		
		Wet/kV	50	55	60		
	50% Impulse	Positive/kV	115	130	160		
		Negative/kV	150	175	205		
Radio-Influence Voltage Date	One-minute Power-Frequency	Dry/kV	65	70	90		
		Wet/kV	45	50	55		
	Impulse/kV	95	110	150			
Power-Frequency Puncture Voltage/kV		150		150		145	
Radio-Influence Voltage Data	Test Voltage to Ground/kV	15	15	15	15	22	22
	Maximum RIV at 1,000kHz/μV	8,000	100	8,000	100	12,000	100
Dimension of Pin Head		Small Steel Head				Large Steel Head	
Net Weight/kg		1.7		2.0		2.3	

NOTE:

- Surfaces coated with semi-conductive glaze considered as effective creepage surfaces and the distance over them is included in the creepage distance.
- RIV data are to be obtained by the test procedures prescribed in section 4.9 of ANSI C29.1

PIN TYPE INSULATOR (BS STANDARD)

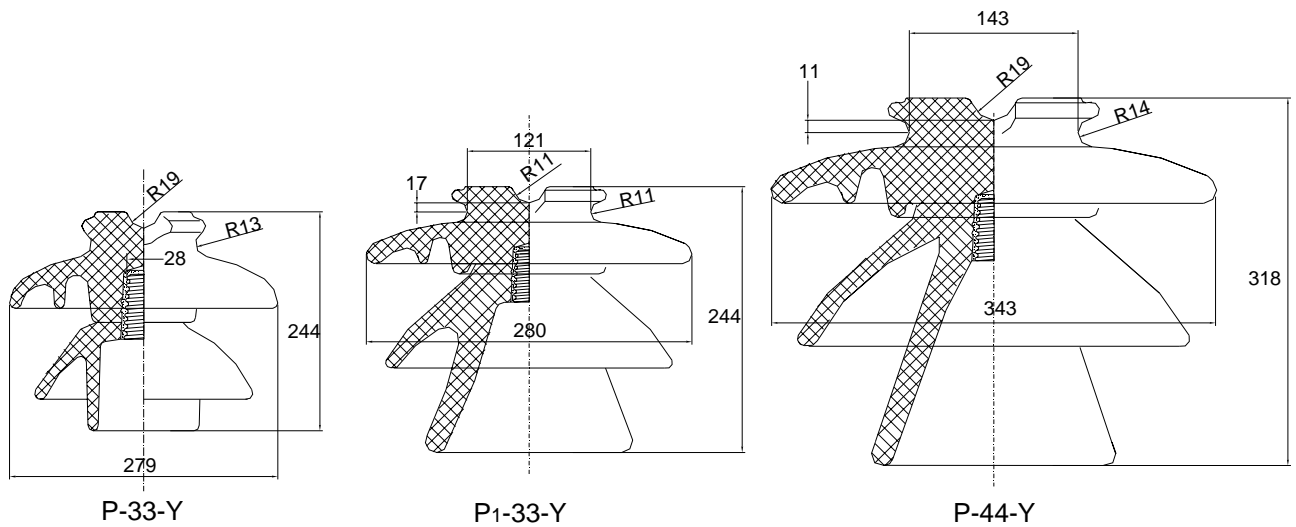

STANDARD PARTICULARS

Cat. No.		0402033		0402033-01		0402044	
BS Class		P-33-Y		P ₁ -33-Y		P-44-Y	
Insulator Type		Plain	Radio Freed	Plain	Radio Freed	Plain	Radio Freed
Recommended Nominal System Voltage/kV		33		33		44	
Total Creepage Distance/mm		630		699		864	
Protected Creepage Distance/mm		381		381		483	
Recommended Pin Height/mm		280		280		330	
Cantilever Strength/kN		11		11		13.6	
Minimum Flashover Voltage	Power-Frequency	Dry/kV	130	130	155		
		Wet/kV	85	95	110		
	50% Impulse	Positive/kV	185	215	240		
		Negative/kV	260	290	305		
Radio-Influence Voltage Data	One-minute Power-Frequency	Dry/kV	110	115	140		
		Wet/kV	75	90	100		
	Impulse/kV	170	200	220			
Power-Frequency Puncture Voltage/kV		185		210		250	
Radio-Influence Voltage Data	Test Voltage to Ground/kV	22	22	30	30	44	44
	Maximum RIV at 1,000kHz/μV	16,000	200	16,000	200	25,000	200
Dimension of Pin Head		Large Steel Head specified in B.S.					
Net Weight/kg		11.5		10.0		13.6	

NOTE:

1. Surfaces coated with semi-conductive glaze considered as effective creepage surfaces and the distance over them is included in the creepage distance.
2. RIV data are to be obtained by the test procedures prescribed in section 4.9 of ANSI C29.1

PIN TYPE INSULATOR (BS STANDARD)

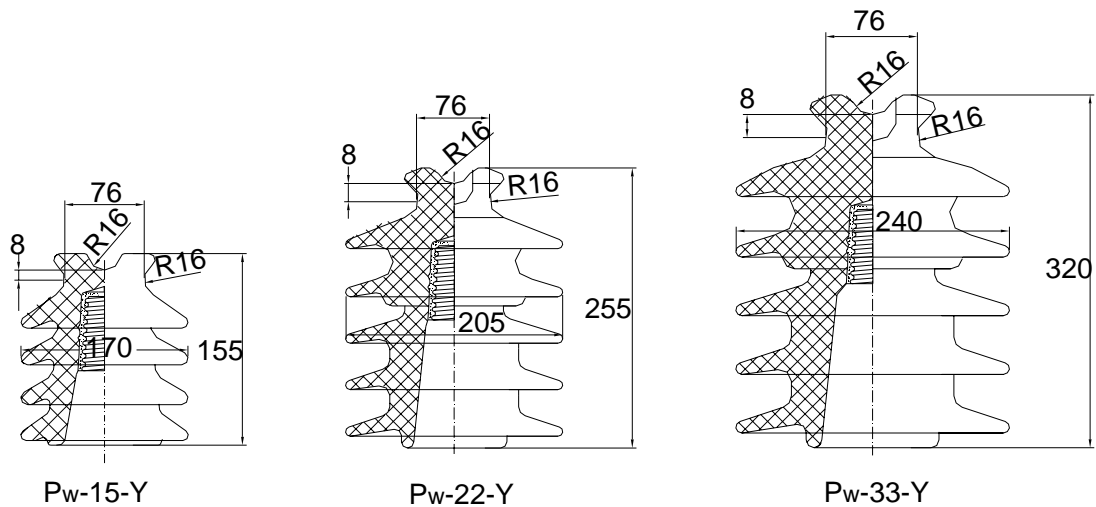

STANDARD PARTICULARS

Cat. No.		0402015-P		0402022-P		0402033-P	
BS Class		Pw-15-y		Pw-22-y		Pw-33-y	
Insulator Type		Plain	Radio Freed	Plain	Radio Freed	Plain	Radio Freed
Recommended Nominal System Voltage/kV		15		22		33	
Total Creepage Distance/mm		432		673		851	
Protected Creepage Distance/mm		197		267		419	
Recommended Pin Height/mm		216		280		330	
Cantilever Strength/kN		11		11		11	
Minimum Flashover Voltage	Power-Frequency	Dry/kV	100	125	140		
		Wet/kV	65	95	110		
Radio-Influence Voltage Data	One-minute Power-Frequency	Positive/kV	150	190	210		
		Dry/kV	90	110	125		
	Wet/kV	60	90	100			
Impulse/kV		140	180	200			
Power-Frequency Puncture Voltage/kV		150		200		210	
Radio-Influence Voltage Data	Test Voltage to Ground/kV	22	22	30	30	44	44
	Maximum RIV at 1,000kHz/ μ V	12,000	100	16,000	200	25,000	200
Dimension of Pin Head		Large Steel Head specified in B.S.					
Net Weight/kg		5		10		13	

NOTE:

1. Surfaces coated with semi-conductive glaze considered as effective creepage surfaces and the distance over them is included in the creepage distance.

2. RIV data are to be obtained by the test procedures prescribed in section 4.9 of ANSI C29.1

PIN TYPE INSULATOR FOR HIGH VOLTAGE (AS STANDARD)

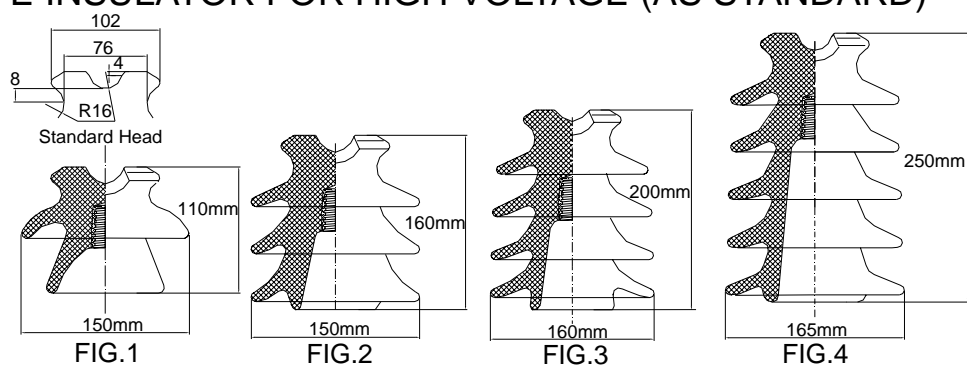

STANDARD PARTICULARS

Cat. No.	0406180	0406275	0406450	0406490
Fig. No.	1	2	3	4
Nominal System Voltage/kV	SLP/11/180	ALP/11/275	ALP/22/450	ALP/22/490
Min. Nominal Creepage Distance/mm	180	275	450	490
Recommended Pin Type	A/130/7	C/150/7	C/200/11	C/200/11
Min. Cantilever Strength/kN	7	7	11	11
Power Frequency Withstand Voltage/kV	30	30	50	50
Lightning Impulse Withstand Voltage/kV	105	105	150	160
Power Frequency Puncture Voltage/kV	95	105	145	160
Weight/kg	1.50	3.2	3.8	4.2

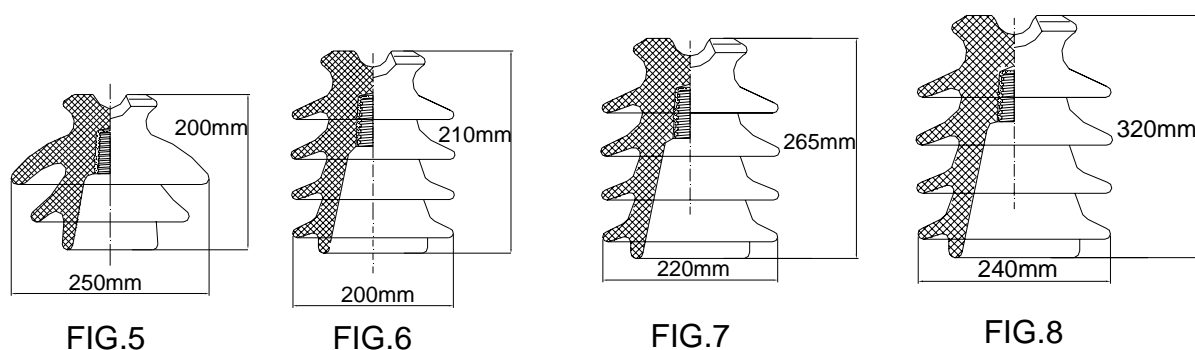

STANDARD PARTICULARS

Cat. No.	0406480	0406520	0406710	0406920
Fig. No.	5	6	7	8
AS Class	ALP/22/480	ALP/22/520	ALP/33/710	ALP/33/920
Nominal System Voltage/kV	22	22	33	33
Min. Nominal Creepage Distance/mm	480	520	710	920
Recommended Pin Type	C/150/11	C/220/11	C/300/7	C/300/7
Min. Cantilever Strength/kN	11	11	11	11
Power Frequency Withstand Voltage/kV	50	50	90	90
Lightning Impulse Withstand Voltage/kV	150	150	220	220
Power Frequency Puncture Voltage/kV	130	160	210	220
Weight/kg	5.4	4.8	10.0	14.3

PIN TYPE INSULATOR FOR HIGH VOLTAGE (DIN STANDARD)

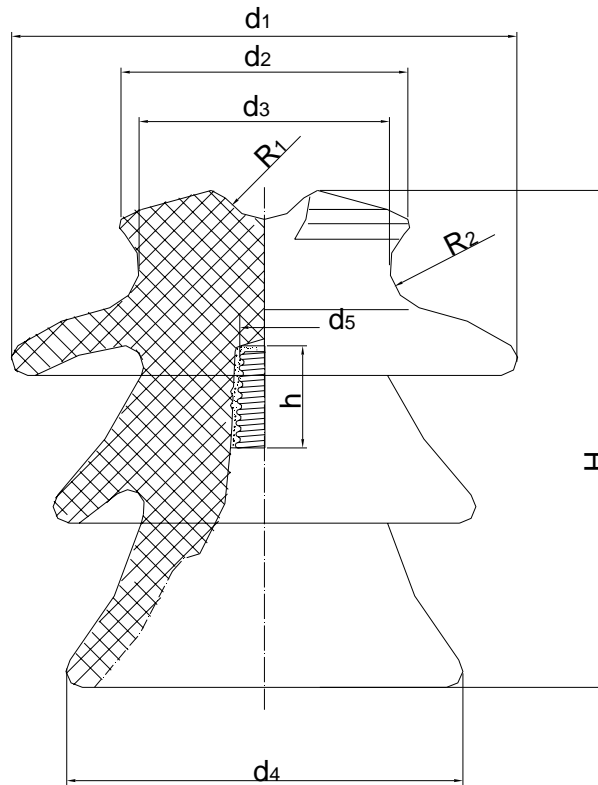

STANDARD PARTICULARS

Cat. No.		0403010	0403015	0403020	0403030	
DIN. No.		St10	St15	St20	St30	
Main Dimension/mm	d ₁	135	150	175	230	
	d ₂	62	72	82	92	
	d ₃	80	90	100	110	
	d ₄	110	120	145	185	
	d ₅	31	28	31	38	
	H	138	158	185	250	
	h	55	60	65	90	
	R ₁	10	10	10	10	
	R ₂	12.5	12.5	12.5	12.5	
Nominal Voltage/kV		10	15	20	30	
Creepage Distance/mm		240	270	340	430	
Power-Frequency Puncture Voltage/kV		110	120	140	165	
Cantilever Failing Load/kN		12.5	12.5	14.7	14.7	
Minimum Flashover Voltage	Power-Frequency	Dry/kV	70	75	90	130
		Wet/kV	70	75	90	130
	50% Impulse	Positive/kV	100	110	130	200
Weight/kg		1.5	2.3	3.4	6.5	