

SPLICING FITTINGS

1. Splicing Sleeve for Steel Wire (hydraulic compression type)

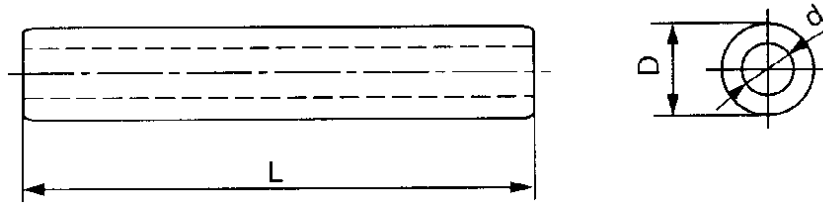

Catalog No.	Suitable Steel Wire	Dimensions (mm)			Slip Strength (KN)	Weight (Kg)
		D	d	L		
JY-35G	GJ-35	16	8.4	220	45	0.3
JY-50G	GJ-50	18	9.6	240	60	0.4
JY-70G	GJ-70	22	11.7	290	88	0.7
JY-100G	GJ-100	26	13.7	320	123	1.0
JY-150G	GJ-150	32	16.5	430	162	2.0

Made of hot-dip galvanized steel.

2. Splicing Sleeve for AAC Conductor (hydraulic compression type)

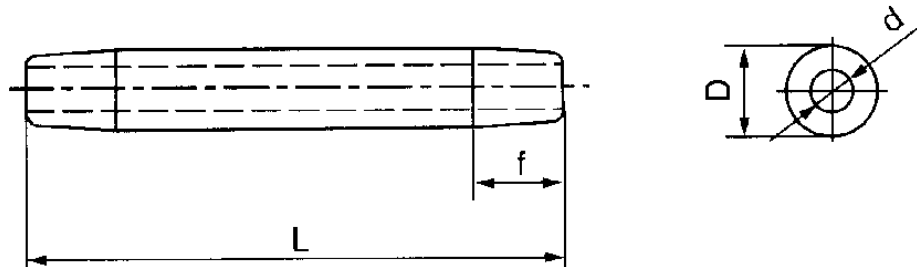

Catalog No.	Suitable Conductor	Dimensions (mm)				Slip Strength (KN)	Weight (Kg)
		D	f	d	L		
JY-150L	LJ-150	30	20	17.0	280	22	0.4
JY-185L	LJ-185	32	20	19.0	310	27	0.5
JY-210L	LJ-210	34	20	20.0	330	31	0.6
JY-240L	LJ-240	36	20	21.5	350	34	0.7
JY-300L	LJ-300	40	25	24.0	390	45	1.
JY-400L	LJ-400	45	25	27.5	450	58	1.2
JY-500L	LJ-500	52	30	30.5	510	73	2.0
JY-630L	LJ-630	60	35	34.5	570	87	3.0
JY-800L	LJ-800	65	40	38.5	650	110	3.8

Made of aluminum.

3. Splicing Sleeve for Insulated Overhead Cable (ABC)

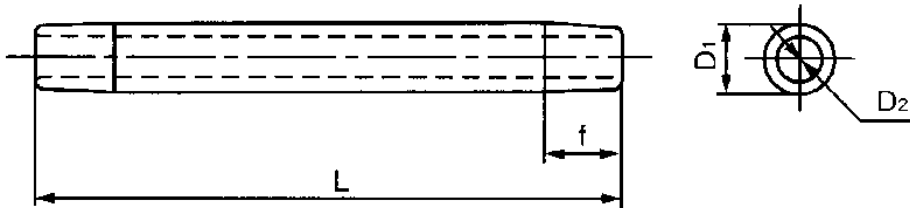

Catalog No.	Suitable Conductor	Dimensions (mm)				Slip Strength (KN)	Weight (Kg)
		D ₁	D ₂	f	L		
JY-35LY	JKLYJ-35	20	7.6	15	130	4.9	0.10
JY-50LY	JKLYJ-50	20	9.0	15	140	6.7	0.10
JY-70LY	JKLYJ-70	22	11.0	15	170	9.8	0.13
JY-95LY	JKLYJ-95	24	12.5	15	190	13.0	0.17
JY-120LY	JKLYJ-120	26	14.0	15	210	16.5	0.22
JY-150LY	JKLYJ-150	28	15.5	20	240	20.0	0.28
JY-185LY	JKLYJ-185	32	17.0	20	260	25.4	0.40
JY-240LY	JKLYJ-240	36	19.5	20	290	33.0	0.50

Made of aluminum. Note: the material for insulation can be supplied.

4. Splicing Sleeve for AS. Stranded Wire

(hydraulic compression type)

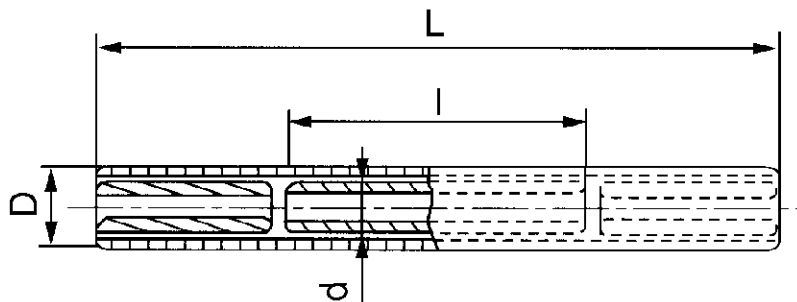

Catalog No.	Suitable Conductor	Dimensions (mm)				Slip Strength (KN)	Weight (Kg)
		D	d	L	l		
JY-50BG	LB20J-50	32	18	440	240	55.8	1.00
JY-70BG	LB27J-70	32	20	550	320	65.8	1.63
JY-80BG	LB20J-80	34	24	550	320	85	2.12
JY-95BG	LB40J-95	34	24	550	330	56	1.66
JY-120BG	LB27J-120	36	26	640	440	112	2.00

The inner sleeve is made of hot-dip galvanized steel. The outer sleeve and lining sleeves are made of aluminum.

5. Splicing Sleeve for Steel Wire (explosive overlap joint)

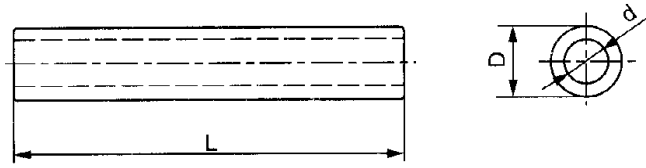

Catalog No.	Suitable Steel Wire	Dimensions (mm)			Slip Strength (KN)	Weight (Kg)
		D	d	L		
JBD-35G	GJ-35	22	16	110	45	0.2
JBD-50G	GJ-50	25	17	130	60	0.3
JBD-70G	GJ-70	28	20	150	88	0.4
JBD-100G	GJ-100	32	23	170	123	0.6

Made of hot-dip galvanized steel.

6. Splicing Sleeve for ACSR Conductor (explosive overlap joint)

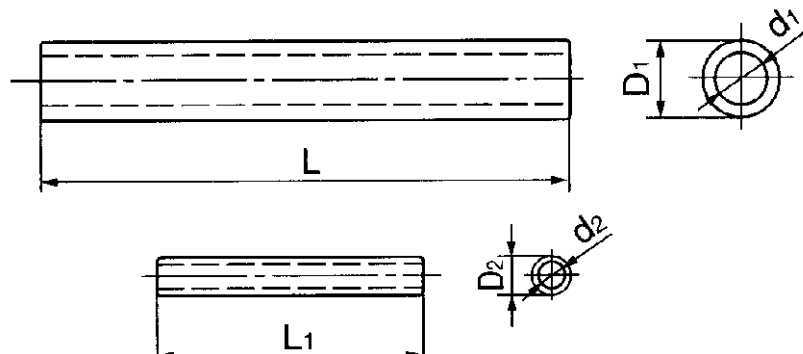

Catalog No.	Suitable Conductor	Dimensions(mm)						Slip Strength (KN)	Weight (Kg)
		D ₁	D ₂	d ₁	d ₂	L	L ₁		
JYB-300/40	LGJ-300/40	40	22	25.5	17	430	120	87	1.1
JYB-300/50	LGJ-300/50	40	22	26.0	17	450	140	98	1.1
JYB-300/70	LGJ-300/70	42	24	27.0	19	510	160	122	1.4
JYB-400/35	LGJ-400/35	45	24	29.0	19	510	120	99	1.4
JYB-400/50	LGJ-400/50	45	24	29.5	19	510	140	117	1.5
JYB-400/65	LGJ-400/65	48	26	29.5	21	520	160	128	1.8
JYB-400/95	LGJ-400/95	48	28	31.0	22	550	170	163	1.9
JYB-500/65	LGJ-500/65	52	24	32.5	19	560	160	146	2.2

The outer sleeve are made of aluminum, inner sleeve is made of hot-dip galvanized steel.

7. Splicing Sleeve for ACSR Conductor (hydraulic overlap joint)

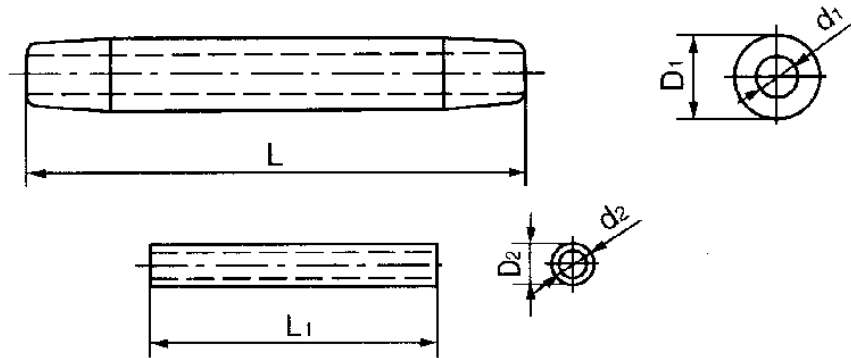

Catalog No.	Suitable Conductor	Dimensions(mm)						Slip Strength (KN)	Weight (Kg)
		D ₁	D ₂	L ₁	L ₂	d ₁	d ₂		
JY-240/30	LGJ-240/30	36	16	570	170	23.0	7.9	70	1.28
JY-240/40	LGJ-240/40	36	16	590	190	23.0	8.7	80	1.33
JY-240/55	LGJ-240/55	36	20	640	230	24.0	10.2	100	1.56
JY-300/15	LGJ-300/15	40	14	560	120	24.5	5.4	65	1.50
JY-300/20	LGJ-300/20	40	14	580	140	25.0	6.3	70	1.52
JY-300/25	LGJ-300/25	40	14	600	160	25.0	7.2	80	1.58
JY-300/40	LGJ-300/40	40	16	640	190	25.5	8.5	90	1.70
JY-300/50	LGJ-300/50	40	18	660	210	26.0	9.6	100	1.79
JY-300/70	LGJ-300/70	42	22	710	260	26.5	11.5	120	2.09
JY-400/20	LGJ-400/20	45	14	580	140	28.5	6.5	85	2.10
JY-400/25	LGJ-400/25	45	14	660	160	28.5	7.3	90	2.12
JY-400/35	LGJ-400/35	45	16	680	180	28.5	8.2	100	2.25
JY-400/50	LGJ-400/50	45	20	730	220	29.5	9.9	120	2.48
JY-400/65	LGJ-400/65	48	22	760	250	29.5	11.0	130	2.73
JY-400/95	LGJ-400/95	48	26	830	300	31.0	13.2	160	3.07
JY-500/35	LGJ-500/35	52	16	740	180	31.5	8.2	110	2.36
JY-500/45	LGJ-500/45	52	18	760	200	31.5	9.1	120	3.12
JY-500/65	LGJ-500/65	52	22	820	250	32.5	11.0	150	3.32
JY-630/45	LGJ-630/45	60	18	840	200	35.5	9.1	140	4.45
JY-630/55	LGJ-630/55	60	20	880	230	36.5	10.3	155	4.67
JY-630/80	LGJ-630/80	60	24	940	280	36.5	12.3	180	5.25

The outer sleeve is made of aluminum, the inner sleeve is made of hot-dip galvanized steel.

8. Splicing Sleeve for ACSR Conductor (hydraulic overlap joint)

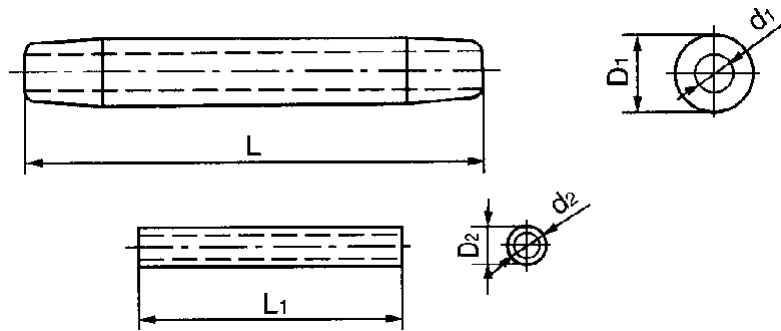

Catalog No.	Suitable Conductor	Dimensions(mm)						Slip Strength (KN)	Weight (Kg)
		D ₁	D ₂	L ₁	L ₂	d ₁	d ₂		
JYD-240/30	LGJ-240/30	36	20	440	80	23.0	12.0	72	0.86
JYD-240/40	LGJ-240/40	36	20	440	80	23.0	13.0	79	0.86
JYD-240/55	LGJ-240/55	36	22	460	100	24.0	16.0	97	0.88
JYD-300/15	LGJ-300/15	40	18	470	50	24.5	8.4	65	1.10
JYD-300/20	LGJ-300/20	40	18	480	60	25.0	9.8	72	1.15
JYD-300/25	LGJ-300/25	40	20	480	70	25.5	11.2	79	1.15
JYD-300/40	LGJ-300/40	40	20	480	80	25.5	13.3	88	1.20
JYD-300/50	LGJ-300/50	40	22	490	100	26.0	15.0	98	1.20
JYD-300/70	LGJ-300/70	42	24	510	110	27.0	18.0	122	1.37
JYD-400/20	LGJ-400/20	45	18	550	60	28.5	9.8	84	1.52
JYD-400/25	LGJ-400/25	45	20	550	70	28.5	11.2	91	1.55
JYD-400/35	LGJ-400/35	45	22	540	80	28.5	13.0	99	1.56
JYD-400/50	LGJ-400/50	45	24	550	100	29.5	15.4	117	1.61
JYD-400/65	LGJ-400/65	48	26	560	110	29.5	17.2	129	1.96
JYD-500/35	LGJ-500/35	52	22	610	80	31.5	13.0	114	2.36
JYD-500/45	LGJ-500/45	52	24	610	90	31.5	14.0	122	2.41
JYD-500/65	LGJ-500/65	52	26	610	110	32.5	17.2	146	2.50
JYD-630/45	LGJ-630/45	60	24	680	90	35.5	14.0	141	3.71
JYD-630/55	LGJ-630/55	60	26	680	100	36.0	16.0	156	3.80

The outer sleeve is made of aluminum, the inner sleeve is made of hot-dip galvanized steel.

9. Splicing Sleeve for ACSR Conductor

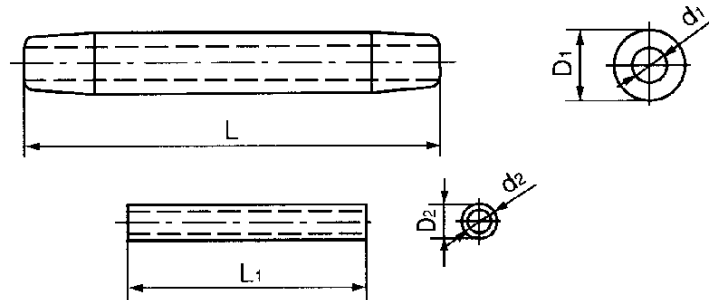

Catalog No.	Suitable Conductor, Code	Dimensions(mm)						Slip Strength (KN)	Weight (Kg)
		D ₁	d ₁	L	D ₂	d ₂	L ₁		
JY-170	LINNET	32	19.5	570	16	7.2	170	60.20	1.35
JY-183	LYNX	32	20.9	590	18	8.9	190	75.71	1.47
JY-240	HAWK	36	23.3	590	18	8.5	190	82.48	1.46
JY-241	HEW	36	23.9	640	20	10.2	230	99.44	1.65
JY-248	LARK	36	21.9	600	20	9.3	210	85.93	1.55
JY-264	BEAR	40	25.1	680	22	10.7	230	105.83	1.91
JY-282	DOVE	40	25.1	660	18	9.2	210	100.64	2.00
JY-306	SQUAB	40	26.2	660	20	9.6	210	102.98	1.91
JY-322	GROSBEAK	40	26.9	680	22	9.9	220	107.17	2.00
JY-376	TEAL	45	27.0	760	22	11.5	260	126.75	2.81
JY-402	CONOOR	45	29.7	730	20	9.8	220	119.29	2.58
JY-428	ZEBRA	48	30.5	740	20	10.1	230	125.31	2.96
JY-445	REDWINE	48	29.3	810	24	12.5	280	146.32	3.28
JY-468	ORAKE	48	30.0	760	22	11.0	250	132.52	2.85
JY-483	RALL	48	30.9	830	26	13.2	300	163.00	3.17
JY-494	MALLARD	48	31.6	740	18	7.9	180	109.60	2.25
JY-546	CAROINAL	52	32.5	820	22	10.8	250	143.52	3.45
JY-564	BLUEJAY	52	34.1	760	18	8.5	200	126.75	3.25
JY-604	GRACKCE	60	36.3	940	24	12.1	280	178.93	5.25

The outer sleeve is made of aluminum, the inner sleeve is made of hot-dip galvanized steel.

10. Splicing Sleeve for ACSR Conductor (compression with pliers)

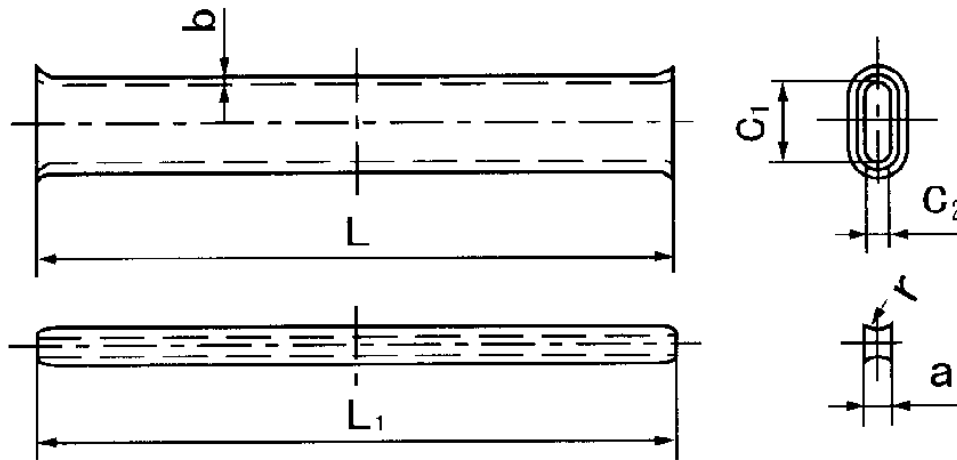

Catalog No.	Suitable Conductor	Dimensions(mm)							Slip Strength (KN)	Weight (Kg)
		a	b	C ₁	C ₂	r	L	L ₁		
JT-10/2	LGJ-10/2	4.0	1.7	11.0	5.0	...	170	180	3.9	0.05
JT-16/3	LGJ-16/3	5.0	1.7	14.0	6.0	...	210	220	5.8	0.07
JT-25/4	LGJ-25/4	6.5	1.7	16.6	7.8	...	270	280	8.8	0.08
JT-35/6	LGJ-35/6	8.0	2.1	18.6	8.8	12.0	340	350	12.0	0.17
JT-50/8	LGJ-50/8	9.5	2.3	22.0	10.5	13.0	420	430	16.0	0.23
JT-70/10	LGJ-70/10	11.5	2.6	26.0	12.5	14.0	500	510	22.0	0.34
JT-95/15	LGJ-95/15	14.0	2.6	31.0	15.0	15.0	690	700	33.0	0.52
JT-95/20	LGJ-95/20	14.0	2.6	31.5	15.2	15.0	690	700	35.0	0.55
JT-120/7	LGJ-120/7	15.0	3.1	33.0	16.0	15.0	910	920	26.0	0.60
JT-120/20	LGJ-120/20	15.5	3.1	35.0	17.0	15.0	910	920	39.0	0.91
JT-150/8	LGJ-150/8	16.0	3.1	36.0	17.5	17.5	940	950	31.0	1.05
JT-150/20	LGJ-150/20	17.0	3.1	37.0	18.0	17.5	940	950	44.0	1.10
JT-150/25	LGJ-150/25	17.5	3.1	39.0	19.0	17.5	940	950	51.0	1.15
JT-185/10	LGJ-185/10	18.0	3.4	40.0	19.5	18.5	1040	1060	39.0	1.40
JT-185/25	LGJ-185/25	19.5	3.4	43.0	21.0	18.0	1040	1060	56.0	1.42
JT-185/30	LGJ-185/30	19.5	3.4	43.0	21.0	18.0	1040	1060	61.0	1.50
JT-210/10	LGJ-210/10	20.0	3.6	43.0	21.0	19.5	1070	1090	43.0	1.52
JT-210/25	LGJ-210/25	20.0	3.6	44.0	21.5	19.5	1070	1090	63.0	1.58
JT-210/35	LGJ-210/35	20.5	3.6	45.0	22.0	19.5	1070	1090	71.0	1.62
JT-240/30	LGJ-240/30	22.0	3.9	48.0	23.5	20.0	540	550	72.0	1.00
JT-240/40	LGJ-240/40	22.0	3.9	48.0	23.5	20.0	540	550	79.0	1.00

Made of aluminum.

11. Splicing Sleeve for Aluminum Conductor (twisting type)

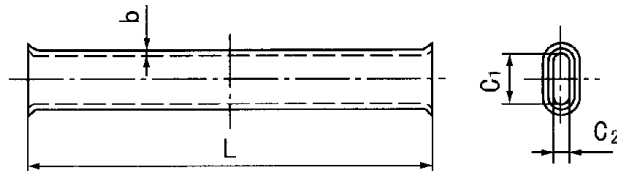

Catalog No.	Suitable Conductor, dia.	Dimensions(mm)				Slip Strength (KN)	Weight (Kg)
		b	C ₁	C ₂	L		
JTJ-21L	L-5.98	1.7	14.41	7.54	279	3.94	0.06
JTJ-34L	L-7.42	1.7	17.05	9.02	356	5.36	0.09
JTJ-54L	L-9.35	1.7	21.69	11.15	457	7.89	0.14
JTJ-67L	L-10.52	1.7	23.55	12.26	508	9.94	0.17
JTJ-85L	L-11.79	1.7	26.57	13.49	559	12.04	0.19
JTJ-107L	L-13.26	1.7	29.31	15.24	610	15.19	0.23
JTJ-135L	L-14.88	1.7	32.87	16.69	686	19.15	0.29
JTJ-170L	L-16.92	2.1	36.20	18.49	737	25.13	0.50
JTJ-202L	L-18.39	2.1	40.03	20.72	864	29.11	0.68
JTJ-241L	L-20.14	2.6	43.00	21.79	940	34.23	0.79
JTJ-282L	L-21.74	2.6	46.51	23.37	1010	239.94	1.00
JTJ-322L	L-23.32	2.6	49.61	25.20	1090	47.56	1.07

Made of aluminum.

12. Splicing Sleeve for ACSR Conductor (twisting type)

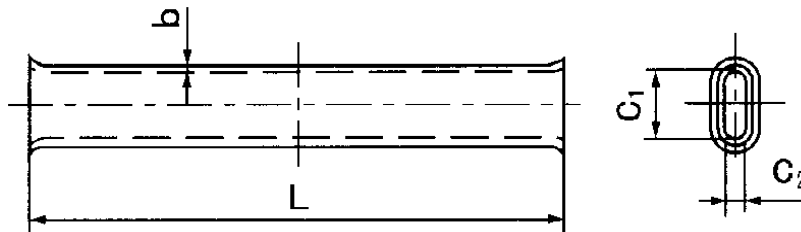

Catalog No.	Suitable Conductor, dia.	Dimensions(mm)				Slip Strength (KN)	Weight (Kg)
		b	C ₁	C ₂	L		
JTJ-13/2	LJ-5.03	1.7	12.9	6.8	250	4.95	0.1
JTJ-13/3	LJ-5.66	1.7	14.4	7.5	275	6.18	0.12
JTJ-24/4	LJ-6.35	1.7	15.8	8.3	305	7.74	0.13
JTJ-27/4	LJ-7.14	1.7	17.2	9.1	356	9.52	0.16
JTJ-34/6	LJ-8.03	1.7	19.3	9.9	381	11.80	0.20
JTJ-54/7	LJ-9.02	1.7	21.2	11.0	432	14.91	0.24
JTJ-54/14	LJ-9.32	1.7	21.7	11.2	457	22.00	0.27
JTJ-54/9	LJ-10.11	1.7	23.1	11.9	483	18.11	0.28
JTJ-67/11	LJ-11.35	1.7	25.4	13.3	533	22.61	0.35
JTJ-85/11	LJ-12.76	1.7	28.4	14.7	584	28.24	0.41
JTJ-107/18	LJ-14.30	1.7	31.9	16.3	660	35.63	0.55

Made of aluminum.

13. Splicing Sleeve for ACSR/AS Conductor

(hydraulic overlap joint)

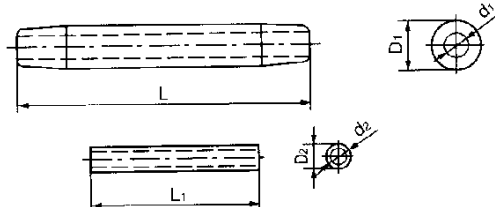

Catalog No.	Suitable Conductor	Dimensions(mm)						Slip Strength (KN)	Weight (Kg)
		D ₁	D ₂	L	L ₁	d ₁	d ₂		
JYD-240/30BG	ACSR/AS-240/30	38	20	450	100	23.0	12.0	72	1.08
JYD-240/40BG	ACSR/AS-240/40	38	22	490	110	23.0	13.0	79	1.18
JYD-240/55BG	ACSR/AS-240/55	38	22	520	150	24.0	16.0	97	1.25
JYD-300/15BG	ACSR/AS-300/15	42	18	520	80	24.5	8.4	65	1.35
JYD-300/20BG	ACSR/AS-300/20	42	20	520	90	25.0	9.8	72	1.40
JYD-300/25BG	ACSR/AS-300/25	42	20	530	100	25.5	11.2	79	1.41
JYD-300/40BG	ACSR/AS-300/40	42	20	540	110	25.5	13.3	88	1.49
JYD-300/50BG	ACSR/AS-300/50	42	22	560	130	26.0	15.0	98	1.60
JYD-300/70BG	ACSR/AS-300/70	45	24	580	160	27.0	18.0	122	2.20
JYD-400/20BG	ACSR/AS-400/20	48	20	580	90	28.5	9.8	84	2.00
JYD-400/25BG	ACSR/AS-400/25	48	20	590	100	28.5	11.2	91	2.05
JYD-400/35BG	ACSR/AS-400/35	48	22	590	100	28.5	13.0	99	2.15
JYD-400/50BG	ACSR/AS-400/50	48	24	600	130	29.5	15.4	117	2.20
JYD-400/65BG	ACSR/AS-400/65	52	26	620	150	29.5	17.2	129	2.70

The outer sleeve is made of aluminum, the inner sleeve is made of hot-dip galvanized steel

14. Splicing Sleeve for ACSR/AS Conductor

(hydraulic overlap joint)

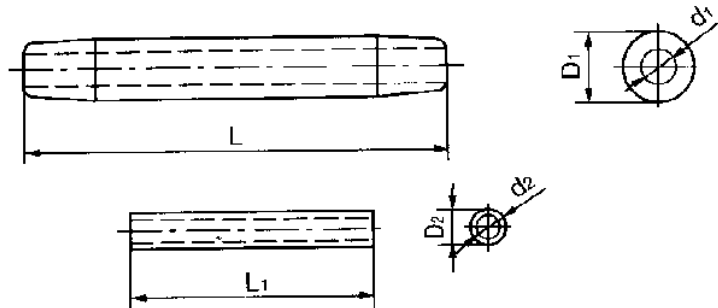

Catalog No.	Suitable Conductor	Dimensions(mm)						Slip Strength (KN)	Weight (Kg)
		D ₁	D ₂	L	L ₁	d ₁	d ₂		
JY-240/30BG	ACSR/AS-240/30	38	20	560	200	23.0	7.9	72	1.35
JY-240/40BG	ACSR/AS-240/40	38	22	610	220	23.0	8.7	79	1.40
JY-240/55BG	ACSR/AS-240/55	38	22	680	300	24.0	10.2	97	1.50
JY-300/15BG	ACSR/AS-300/15	42	18	610	160	24.5	5.4	65	1.60
JY-300/20BG	ACSR/AS-300/20	42	20	620	180	25.0	6.3	72	1.70
JY-300/25BG	ACSR/AS-300/25	42	20	640	200	25.5	7.1	79	1.75
JY-300/40BG	ACSR/AS-300/40	42	20	660	220	25.5	8.5	88	1.80
JY-300/50BG	ACSR/AS-300/50	42	22	700	260	26.0	9.5	98	1.90
JY-300/70BG	ACSR/AS-300/70	45	24	750	320	27.0	11.5	122	2.20
JY-400/20BG	ACSR/AS-400/20	48	20	680	180	28.5	6.3	84	2.10
JY-400/25BG	ACSR/AS-400/25	48	20	700	200	28.5	7.1	91	2.20
JY-400/35BG	ACSR/AS-400/35	48	22	700	200	28.5	8.0	99	2.45
JY-400/50BG	ACSR/AS-400/50	48	24	740	260	29.5	9.5	117	2.60
JY-400/65BG	ACSR/AS-400/65	52	26	780	300	29.5	11.0	129	2.80

The outer sleeve is made of aluminum, the inner sleeve is made of hot-dip galvanized steel

15. Repair Sleeve for ACSR, AAC, AAAC Conductor

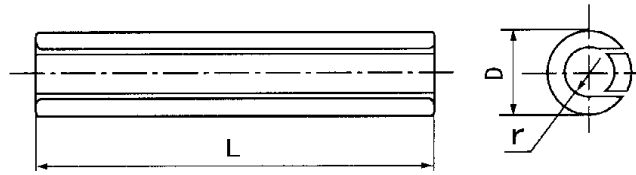

Catalog No.	Suitable Conductor, dia.	Dimensions(mm)			Weight (Kg)
		D	L	r	
JX-95/55	15.70-16.79	32	150	9.0	0.25
JX-185/10	17.01-18.09	32	150	10.0	0.20
JX-185	18.10-19.60	32	150	10.5	0.20
JX-210	20.00-20.90	34	200	11.0	0.29
JX-240	21.00-22.50	36	200	12.0	0.33
JX-240/55	22.60-23.00	40	200	12.5	0.31
JX-300/15	23.01-24.00	40	250	13.0	0.52
JX-300	24.10-25.10	42	250	13.5	0.51
JX-300/70	25.20-26.50	45	300	14.5	0.55
JX-400	26.51-27.20	45	300	14.5	0.75
JX-400/50	27.21-27.90	48	300	15.0	0.90
JX-400/65	27.91-29.00	48	300	15.5	0.90
JX-400/95	29.10-29.90	52	300	16.0	0.85
JX-500	29.91-31.00	52	300	18.0	1.07
JX-630	31.01-34.90	60	350	18.0	1.70
JX-800/55	35.01-38.60	65	350	20.0	1.9
JX-800	36.61-39.00	65	350	20.5	1.9

Made of aluminum.

16. Repair Sleeve for Steel Wire

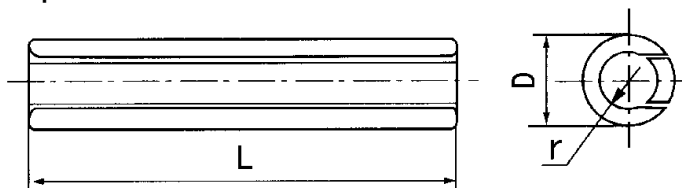

Catalog No.	Suitable Steel Wire, mm ²	Dimensions(mm)			Weight (Kg)
		D	L	r	
JX-35G	GJ-35	16	120	4.2	0.11
JX-50G	GJ-50	18	120	4.8	0.14
JX-70G	GJ-70	22	140	5.8	0.25
JX-80G	GJ-80	24	140	6.2	0.40
JX-100G	GJ-100	26	140	7.0	0.41
JX-150G	GJ-150	32	200	8.4	0.90

Made of hot-dip galvanized steel.

17. Parallel Groove Clamp

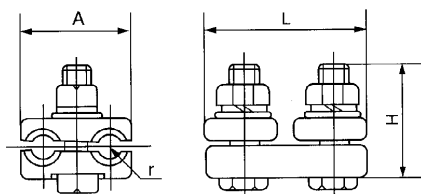

Catalog No.	Conductor Area (mm ²)	Dimensions(mm)				Weight (Kg)
		A	L	r	H	
JB-0	16~25	38	72	3.5	42	0.2
JB-1	35~50	46	80	5.0	53	0.4
JB-2	70~95	54	114	7.0	65	0.7
JB-3	120~150	64	140	8.5	70	1.1
JB-4	185~240	72	144	11.0	75	1.3
JB-5	300~400	100	215	15.0	100	3.9
JB-6	500~600	110	230	18.0	120	5.1

The body and keepers are made of aluminum alloy, other parts are made of hot-dip galvanized steel.

18. Parallel Groove Clamp

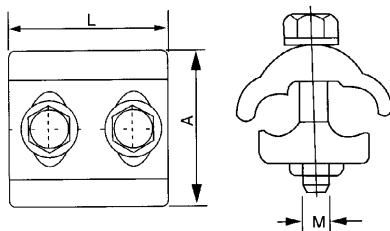

Catalog No.	Suitable Conductor, dia. (mm)		Dimensions(mm)			Weight (Kg)
	Run	Tap	L	A	M	
JBL-11	6.8~11.5	6.8~11.5	60	45	10	0.25
JBL-22	10.1~15.3	11.1~15.3	80	52	10	0.32
JBL-33	15.6~20.1	15.6~20.1	110	66	12	0.62
JBL-44	19.0~24.0	19~24.0	120	76	16	0.82
JBL-55	23.0~29.0	23.0~29.0	140	86	16	1.10
JBL-12	10.1~15.3	6.8~11.5	80	50	10	0.30
JBL-23	15.6~20.1	10.1~15.3	110	58	12	0.60
JBL-34	19.0~24.0	15.6~20.1	120	72	16	0.75
JBL-45	23~29.0	19.0~24.0	140	86	16	1.0
JBL-24	19.0~24.0	10.1~15.3	120	66	16	0.70
JBL-35	23.0~29.0	15.6~20.1	140	85	16	0.90

The body and keepers are made of aluminum alloy, other parts are made of hot-dip galvanized steel.

19. Parallel Groove Clamp for Steel Wire

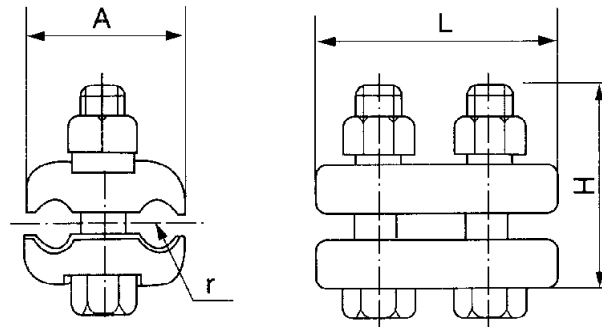

Catalog No.	Steel Wire Area (mm ²)	Dimensions (mm)				Weight (Kg)
		A	L	r	H	
JBB-1	25~35	44	90	4.5	48	0.7
JBB-2	50~70	50	90	6.0	60	1.0
JBB-3	100~120	56	124	7.0	65	1.9

The body and keeper are malleable iron, hot-dip galvanized.

20. Wedge Parallel Groove Clamp (ejection type)

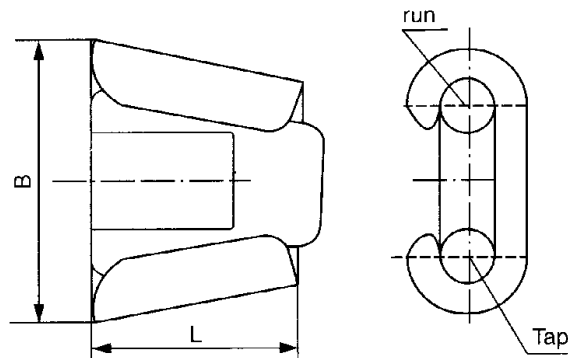

Catalog No.	Conductor, dia. (mm)		Dimensions (mm)		Weight (Kg)
	Run	Tap	L	B	
JBX-70/25	10.5~11.5	6.4~7.4	42	64	0.21
JBX-120/25	15.0~16.0	6.4~7.4	42	64	0.19
JBX-70/70	10.5~11.5	10.5~11.5	42	64	0.20
JBX-120/70	15.0~16.0	10.5~11.5	42	64	0.18
JBX-150/70	16.2~17.2	10.5~11.5	42	64	0.22
JBX-120/120	15.0~16.0	15.0~16.6	42	64	0.17
JBX-150/120	16.2~17.2	15.0~16.0	50	70	0.20
JBX-150/50	16.2~17.2	9.5~10.5	50	70	0.24

The body and tongue are made of forged aluminum alloy.

21. S-Parallel Groove Clamp (compression type)

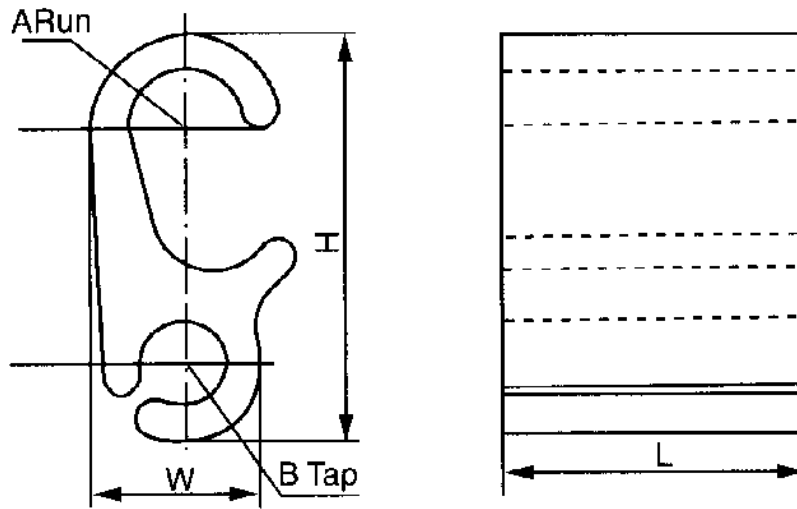

Catalog No.	Run A(mm)	Tap B(mm)	Dimensions (mm)			Weight (Kg)
			H	L	W	
JBS-12	10.0~12.0	7.0~8.3	44	40	24	0.1
JBS-23	12.1~14.1	10.0~12.0	48	40	24	0.2
JBS-34	14.2~17.4	12.1~14.1	70	55	30	0.3
JBS-45	17.5~20.1	14.2~17.4	98	60	32	0.5

Material: aluminum for use on AAC,ACSR conductors.

22. C-Shape Copper Wire Clamp (compression type)

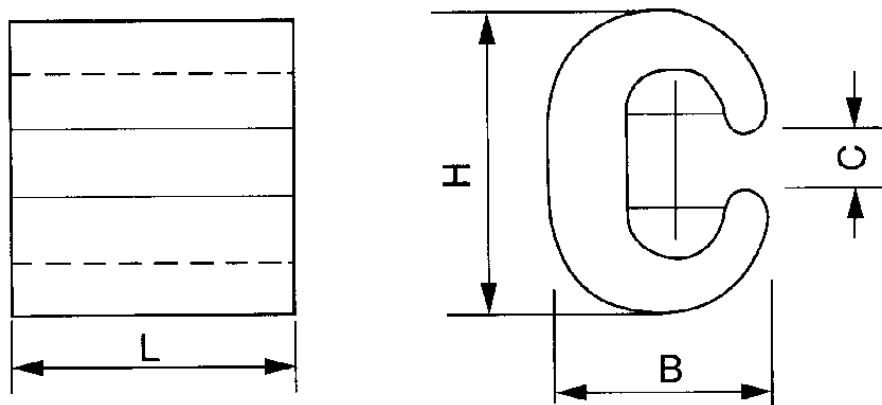

Catalog No.	Suitable Conductor		Dimensions (mm)				Weight (Kg)
	Run	Tap	H	B	L	C	
JCT-1	5.03~6.35	4.65~6.35	25	15	20	10	0.06
JCT-2	5.89~8.13	5.03~8.13	29	17	22	12	0.12
JCT-3	8.15~10.52	6.35~10.52	35	19	25	14	0.14
JCT-4	10.54~13.25	8.13~13.25	40	21	30	16	0.16

Material: copper, suitable for the connection of copper stranded wire.

23. C-Shape Aluminum Wire Clamp (compression type)

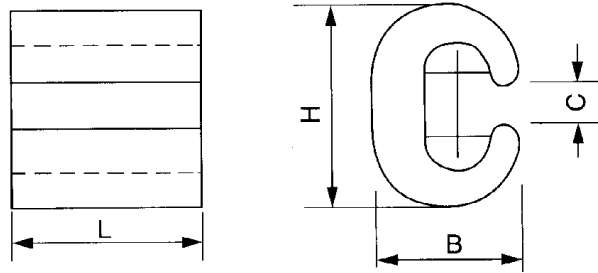

Catalog No.	Suitable Conductor		Dimensions (mm)				Weight (Kg)
	Run	Tap	H	B	L	C	
JCT-1	5.03~6.35	4.65~6.35	36	17	32	16	0.03
JCT-2	5.89~8.13	5.03~8.13	34	20	38	12	0.04
JCT-3	8.15~10.52	6.35~10.52	38	23	45	14	0.05
JCT-4	10.54~13.25	8.13~13.25	46	28	55	16	0.07
JCT-5	13.30~15.06	10.52~15.06	53	30	64	18	0.09
JCT-6	15.01~16.91	13.25~16.91	58	32	70	20	0.11
JCT-7	17.00~18.80	15.06~18.80	64	35	76	22	0.13

Material: aluminum for use on AAC,ACSR conductors.

24. H-Parallel Groove Clamp (compression type)

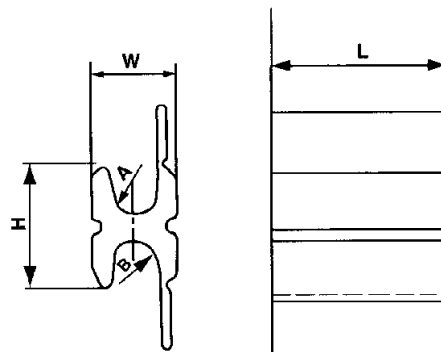

Catalog No.	Suitable Conductor		Dimensions (mm)			Weight (Kg)
	A Run	B Tap	H	L	W	
JH-11	6.8~10.5	6.8~10.5	28	38	18	0.05
JH-22	10.1~14.3	10.1~14.36	33	44	18	0.07
JH-33	14.6~18.1	14.6~18.1	52	89	32	0.39
JH-44	18.5~22.7	18.5~22.7	77	117	44	0.96
JH-55	22.5~28.1	22.5~28.1	80	130	48	1.20
JH-12	10.5~14.0	36.8~10.5	32	44	18	0.06
JH-23	14.9~08.1	10.1~14.3	52	89	32	0.36
JH-34	18.5~22.7	14.6~18.1	77	117	44	0.96
JH-45	22.5~28.1	18.5~22.7	80	130	48	1.20
JH-24	18.5~22.7S	10.1~14.3	77	117	44	1.05

Material: aluminum for use on AAC,ACSR conductors.